



ALHURA.

# TRACK PORTABICI DA TETTO

ALUMINIUM RAIL

- I ISTRUZIONI
- EN INSTRUCTION
- ES INSTRUCCIONES



100% MADE IN ITALY



**Q.TY**

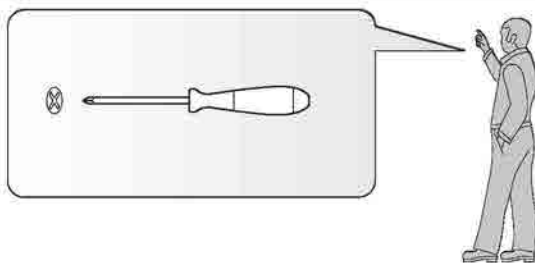

**x1**



**x1DX**



**x1DX**



**x1SX**



**x1SX**



**x2**



**x1**



**x2**



**x4**



**x4**

# COMPONENTI

Components



**2.17 kg.**



**MAX 17 kg.**



**x2**



**x2**



**x1**



**x1**



**x1**

**1**

Utilizzare • To use



**1a**

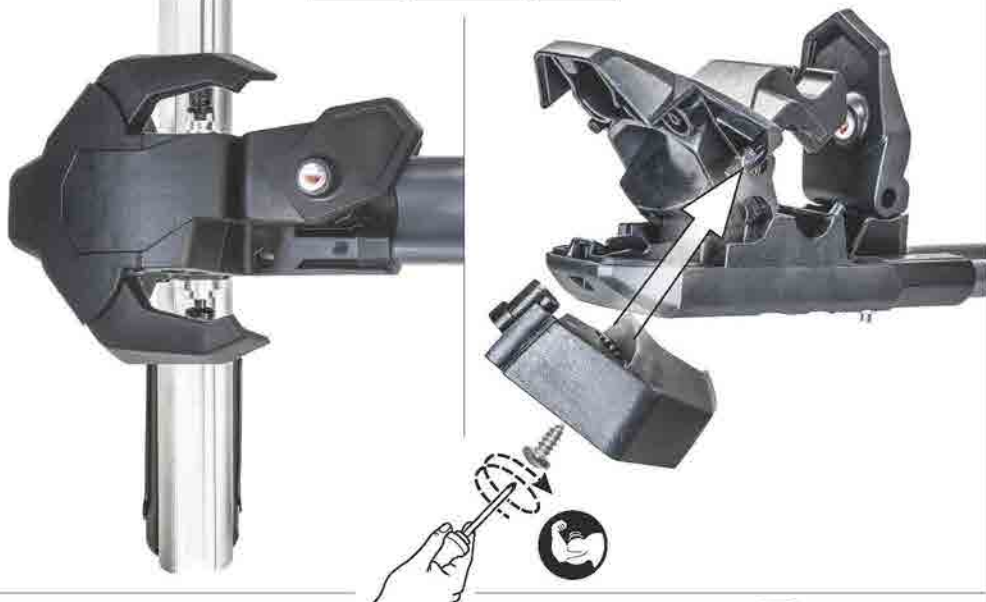

**1b**



## PREPARAZIONE SENZA ANTIFURTO

No lockable system

2

Utilizzare • To use



2a



3



**4****x2****4a****4b**

## MONTAGGIO PORTABICI SULLE BARRE

Cycle rack roof bars fixing

5



5a

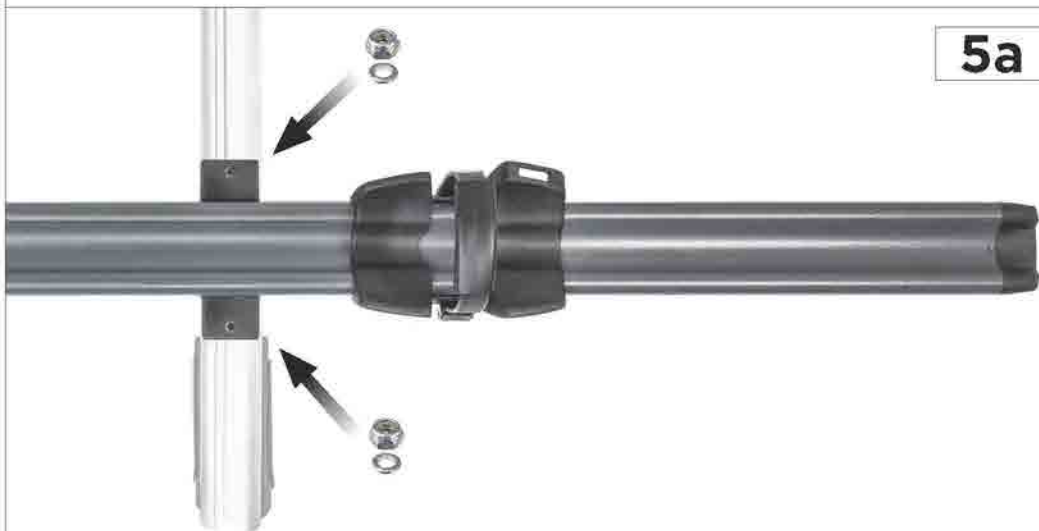

5b



**6****6a****6b****6c**



# UTILIZZO CON ANTIFURTO

Conditions of use ( lockable system )

7



7a

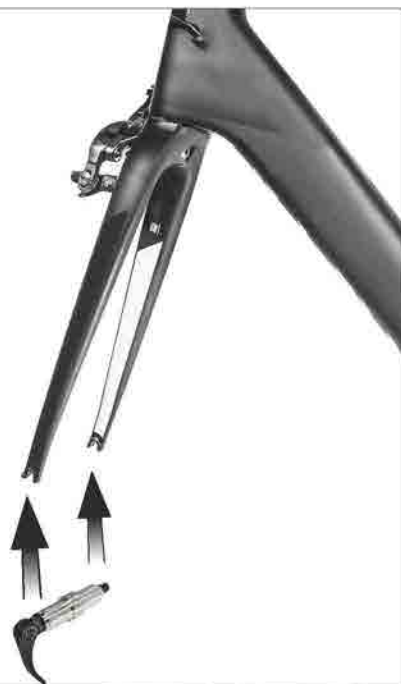

7b



7c

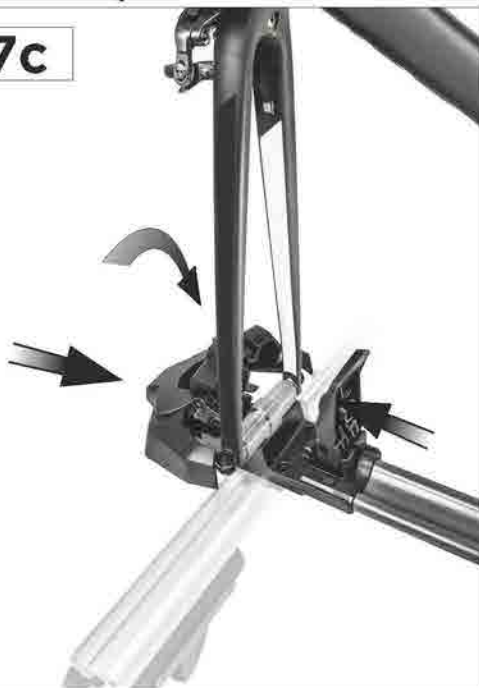

**7d**



**7e**



**8**



# UTILIZZO PERNO PASSANTE

Thru axles use

## • optional •



**Ø12 x 100** (cod. 1766708)



**Ø15 x 100** (cod. 1766706)



**Ø15 x 110** (BOOST)  
(cod. 1766707)



**Ø20 x 110** (cod. 1766705)

9



9a



**9b**

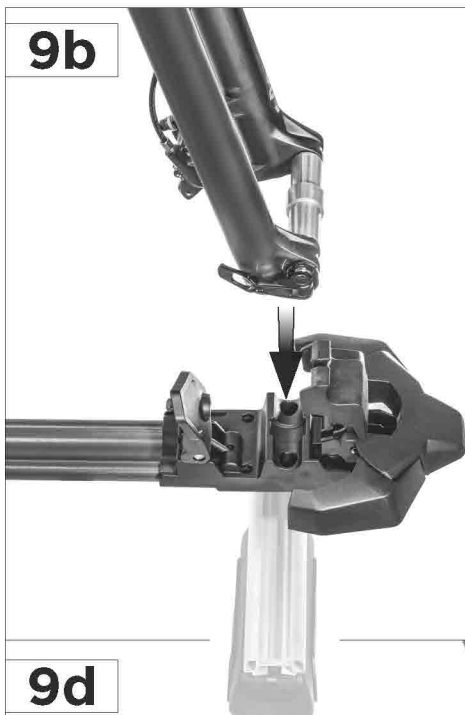

**9c**

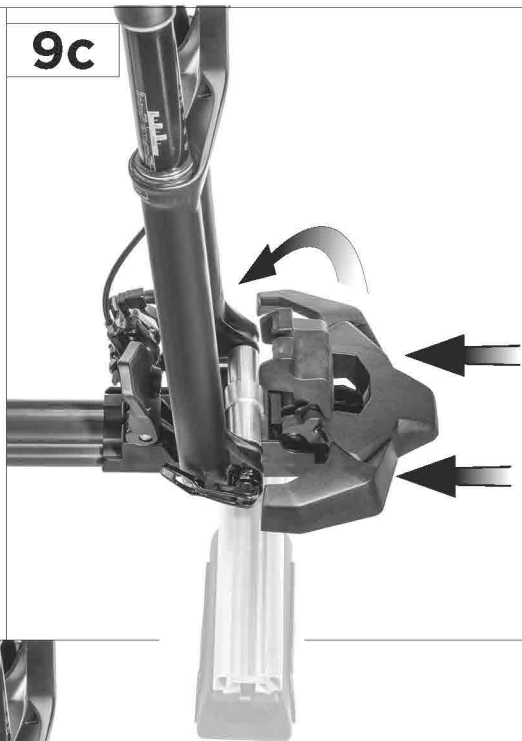

**9d**

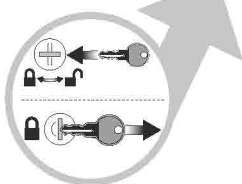
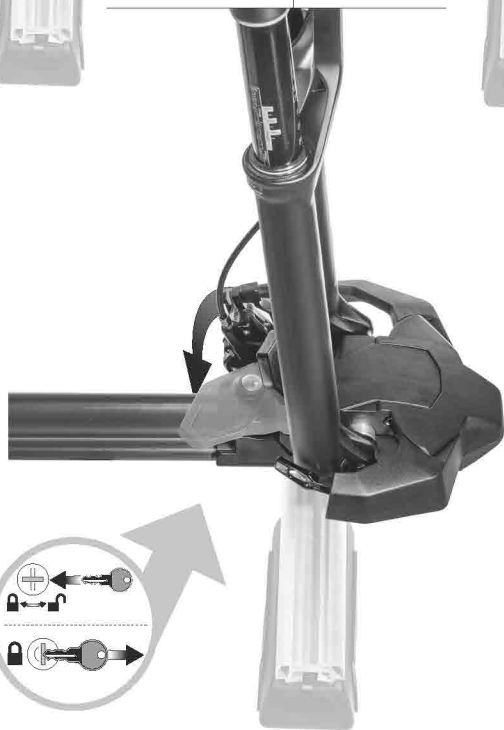

# FISSAGGIO CON CAVALLOTTO

Bar adapter use

<b>Optional</b> (cod. 1774005)	 <b>x3</b>		 <b>x4</b>	 <b>x2</b>
	 <b>x6</b>	 <b>x6</b>		



**10b**

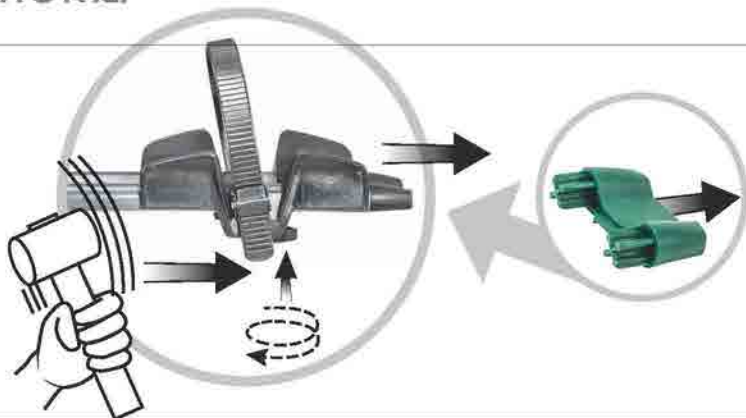

**10c**



**10d**

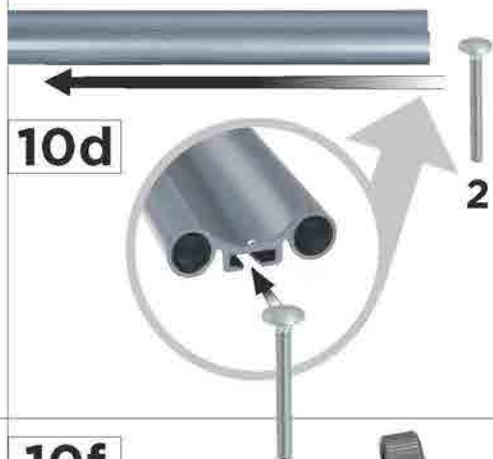

**10e**



**10f**



**ATTENZIONE!!**

Caution!!

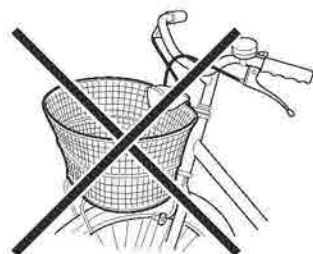
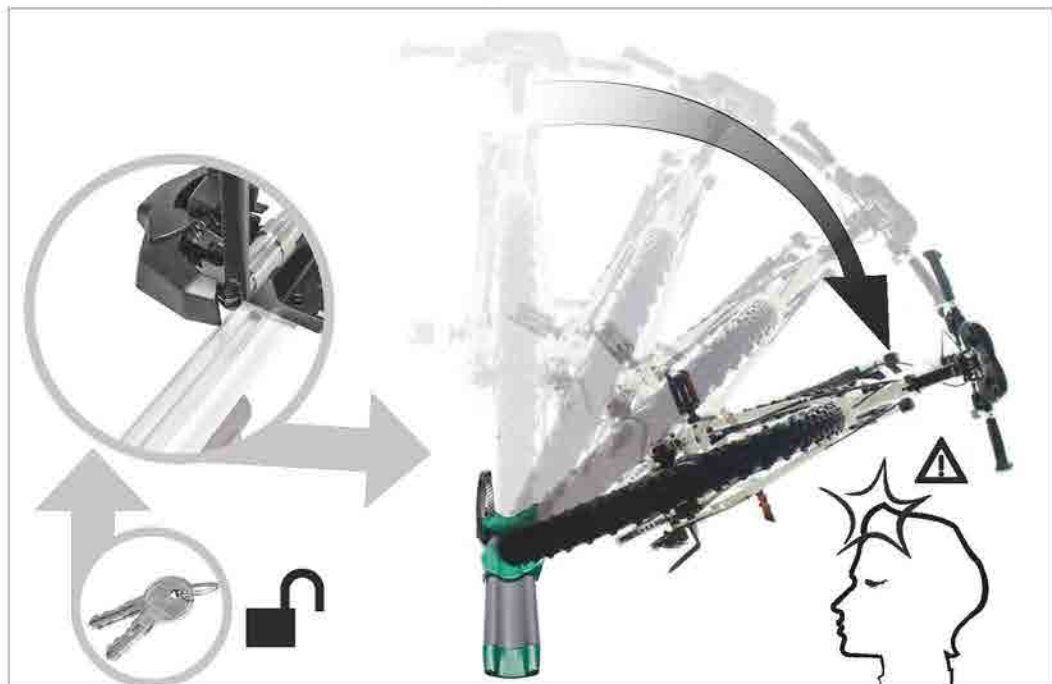

**ATTENTION!!**

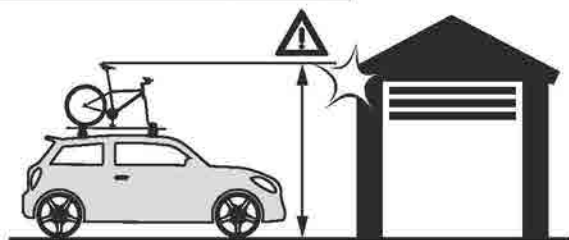

**IT** **OGNI VOLTA CHE SI USA QUESTO PRODOTTO RICORDARSI ATTENTAMENTE QUANTO SOTTO RIPIORTATO, VI RICORDO CHE IL PORTABICI È UN PRODOTTO SICURO SE USATO CORRETTAMENTE, AL CONTRARIO SE USATO MALE PUÒ ARRECARRE GRAVI DANNI A VOI E A CHI VI SEGUE IN STRADA.**

## **ATTENZIONE: NORME DI SICUREZZA**

- Assicurarsi che il portabici sia montato correttamente sulla vettura (vedi istruzioni allegate).
- Bloccare la bicicletta al morsetto e fissare la ruota esclusivamente con la cinghietta in dotazione (vedi istruzioni allegate).
- Viaggiare a velocità moderata e fare attenzione al fondo stradale, in particolare in prossimità di curve, dossi, ecc.
- Tenere presente che il peso delle biciclette modifica il comportamento dell'auto, in particolare con presenza di vento laterale ed in curva.
- Controllare prima di ogni viaggio e ad ogni sosta la tenuta della bicicletta, il fissaggio della cinghietta ruota e il fissaggio del portabici alle barre portatutto.
- **Tenere presente le indicazioni del fabbricante del veicolo e delle barre in merito al carico ammesso sul tetto.**
- Controllare che le biciclette non sporgano oltre l'ingombro dell'auto, come ad esempio manubrio e pedali.
- Stare attenti all'ingombro in altezza specialmente in prossimità di garage, gallerie, rami, ecc.
- Non Portare biciclette con seggiolini portabimbo, coperture parapigioggia o altri elementi che possono ostacolare il passaggio dell'aria.
- Non fare brusche frenate o forti accelerate.
- Non caricare prodotti che non siano biciclette, si ricorda massimo 1 bicicletta (max 17 Kg).
- In caso di componenti usurati o non funzionanti rivolgersi direttamente al rivenditore per la loro sostituzione. Fare attenzione in particolare alla cinghietta di fissaggio della ruota in quanto maggiormente soggetta ad usura. Si raccomanda di non utilizzare alcun tipo di fissaggio improvvisato.
- Per un corretto risparmio energetico smontare il portabici quando non viene utilizzato e riporlo in ambienti asciutti e non soleggiati. In caso di un lungo periodo di non utilizzo del prodotto si raccomanda di procedere ad una verifica dell'idoneità di tutti i componenti prima dell'uso.
- In caso di biciclette con forcelle o telai in carbonio, verificare con il produttore o il rivenditore della bicicletta se è possibile utilizzare il portabici.

## **SI RACCOMANDA DI CONSERVARE LE ISTRUZIONI DI USO DEL PRODOTTO E DI CONSULTARLE AD OGNI UTILIZZO**

**Il fabbricante non è responsabile dei danni causati da un uso non conforme alle istruzioni allegate ed al non rispetto delle norme di sicurezza sopra elencate.**  
**ATTENZIONE: attenersi alla normativa del codice stradale vigente nello stato in cui si usa il portabici.**



**EN**

**PLEASE READ THESE INSTRUCTIONS EACH TIME BEFORE YOU USE THIS PRODUCT, YOU SHOULD REMEMBER THAT A BICYCLE CARRIER IS A SAFE PRODUCT WHEN USED CORRECTLY BUT CAN BE THE OPPOSITE IF USED INCORRECTLY AND COULD CAUSE SERIOUS DAMAGE TO OTHER ROAD USERS.**

## **WARNING: SAFETY RULES**

- Ensure the bike carrier is installed on the vehicle in accordance with our instructions (see attached instructions)
- The bike should be held securely by the clamp and the wheel located using only the strap provided (see attached instructions)
- Moderate your speed and be especially careful over badly surfaced roads and in particular when cornering
- Bear in mind the weight of the bike will change how your vehicle handles, particularly in side winds and on when cornering.
- Before leaving on a trip and at each stop check that the bike is securely fixed to the carrier, that the strap are secured to the wheel and that the carrier is tightly secured to the roof bars.
- **Do not exceed the maximum weight recommendations of the vehicle manufacturer and the roof bar manufacturer.**
- Make sure that the bikes or parts of them, such as the handlebars or pedals, do not protrude beyond the extreme width of either side or end of the vehicle.
- Always bear in mind the extra height, especially when negotiating garages, bridges, tunnels, tree branches etc.
- Remove from your bike all child seats, panniers, saddle bags and any other objects that increase wind resistance.
- Do not accelerate quickly or brake suddenly.
- Do not use the carrier for anything except bicycles, remember 1 bike only (max 17 kg).
- Should any part of the carrier show signs of wear or incorrect working please contact your retailer for replacement. Particular attention should be paid to the strap holding the wheel which can be subject to wear. Do not substitute any part with non genuine parts.
- To save energy and money remove the carrier when not in use. Store in a clean, dry place out of direct sunlight. Should you not use the carrier for any length of time please check all components are working properly before use.
- In the case of bikes with carbon frames or forks, always consult the bike manufacturer or dealer to check if you are allowed to use the carrier.

**WE RECOMMEND YOU KEEP THESE INSTRUCTIONS IN A SAFE PLACE AND READ THEM EACH TIME YOU USE THE CARRIER.**

**We, the manufacturers do not accept any responsibility for the misuse of this product, or a use not in accordance with our instructions. WARNING: Keep within the laws of the country in which you are using the bike carrier.**

**ES**

**CADA VEZ QUE UTILICE ESTE PRODUCTO, SIGA ATENTAMENTE LAS INDICACIONES DADAS A CONTINUACIÓN. SE RECUERDA QUE EL PORTABICICLETAS ES UN PRODUCTO SEGURO SI SE UTILIZA CORRECTAMENTE, PERO SI SE HACE UN MAL USO DE ÉL PUEDE OCASIONARLE GRAVES DAÑOS A USTED Y A QUIEN LE SIGUE POR LA CARRETERA.**

## **ATENCIÓN: NORMAS DE SEGURIDAD**

- Asegúrese de que el portabiciquetas esté montado correctamente sobre el coche (vea las instrucciones adjuntas).
- Fije la bicicleta a la mordaza y sujete las ruedas únicamente con las correas suministradas (vea las instrucciones adjuntas).
- Viaje a una velocidad moderada y preste atención al firme de la carretera, especialmente cerca de curvas, badenes, etc.
- Tenga en cuenta que el peso de las bicicletas afecta al comportamiento del coche, especialmente si hay viento lateral y en las curvas.
- Compruebe antes de cada viaje y en cada parada la sujeción de la bicicleta, el amarre de las correas de la rueda y la fijación del portabiciquetas a las barras de techo.
- **Tenga en cuenta las indicaciones del fabricante del vehículo y de las barras respecto a la carga máxima admitida sobre el techo.**
- Compruebe que las bicicletas no sobresalgan respecto a las dimensiones del coche (por ejemplo, manubrio y pedales).
- Preste atención a las dimensiones en altura, especialmente cerca de garajes, túneles, ramas de árboles, etc.
- No transporte bicicletas con sillas portabebé, cubiertas para lluvia u otros elementos que puedan obstaculizar el paso del aire.
- Evite realizar frenadas bruscas o fuertes acelerones.
- No cargue productos que no sean bicicletas. Se recuerda que el máximo es 1 bicicleta (máx. 17 Kg).
- En caso de componentes desgastados o que no funcionen, acuda directamente al distribuidor para su sustitución. Preste especial atención a las correas de sujeción de la rueda, ya que están más expuestas al desgaste. No utilice ningún tipo de sujeción improvisada.
- Para favorecer el ahorro de energía, desmonte el portabiciquetas cuando no se use y consérvelo en ambientes secos y no expuestos a la luz directa del sol. Si no se usa el producto durante un largo periodo, antes de volver a utilizarlo será necesario comprobar que todos los componentes sean aptos para su uso.
- En el caso de las bicicletas con horquillas o cuadros de carbono, consulte siempre al fabricante o distribuidor de la bicicleta para comprobar que se puede utilizar el portabiciquetas.

## **CONSERVE LAS INSTRUCCIONES DE USO DEL PRODUCTO Y CONSÚLTelas CADA VEZ QUE LO USE**

**El fabricante no se responsabiliza de los daños ocasionados por un uso no conforme a las instrucciones adjuntas y por el incumplimiento de las normas de seguridad expuestas. ATENCIÓN: respete la normativa del código de circulación vigente en el país en el que se use el portabiciquetas.**



**NOTE**

